

### Totalizer Quick Setup Guide For C150, C160, C1900, 1492, SR/PR100, SR/PR250

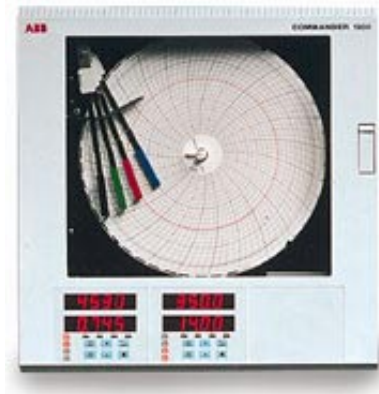

#### Description:

This technote explains how to setup the totalizer in the Commander C150, C160 and C1900, 1492, SR/PR100, SR/PR250 Controllers and Recorder.

#### Applies to:

Commander C150, C160 and C1900, 1492, SR/PR100, SR/PR250 Controllers and Recorder instruments configured from the frontface.

#### Explanation and Solution:

##### Step 1:

The first step in configuring the totalizer is to obtain the flow calibration records. This information is usually located on the transmitter body. An example is 4-20 mA= 0 to 2000 GPM (gallons per minute).

##### Step 2:

The next step is to configure the instrument with this calibration information. The following sections explain how to configure the various controllers/recorders with the calibration information.

##### **C 150 and C 160:**

In the LEVEL 4 in the configuration mode, specify ENG LO and ENG HI. ENG LO is the low engineering range (0 in the above example) and ENG HI is the high engineering range (2000 in the above example).

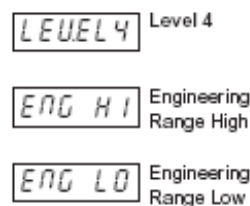

**C 1900:**

This is done at the Basic Configuration menu (BASIC COOnFIG).

Go to the SET UP INPUT section and specify high engineering range as the ENG-HI. This is 2000 in the above example.

Specify the Lo engineering range as ENG-LO.

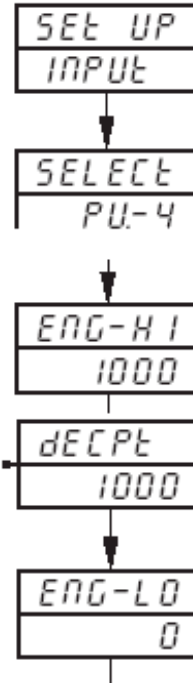

**1492:**

In the PROGRAMME CHANNEL section, specify the high engineering range as the PROGRAM CHANNEL X – SETUP DISPLAY X – X DISPLAY FS.

Specify the low engineering range as the ZERO.

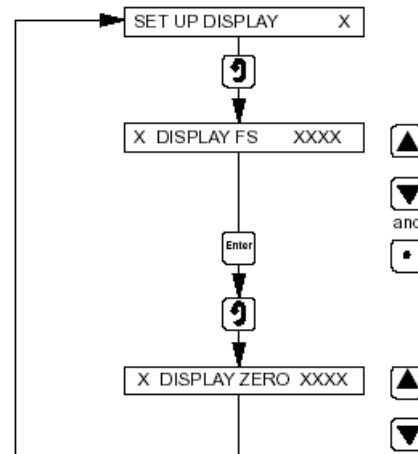

**SR 250A and PR 250**

This is done in the Configuration mode. Go to the Inputs Set Up menu and specify the low and high engineering ranges as the Eng Lo/Hi.

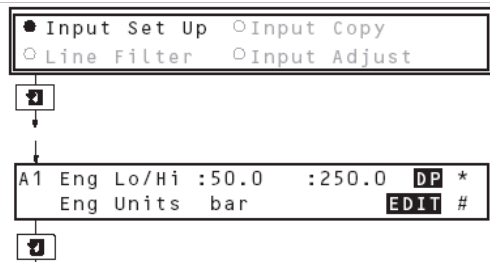

**SR 100A**

This is done at the CONFIGURATION – BASIC LEVEL.

In the ANALOG INPUT menu, specify the high engineering range (2000 in the above example) as the ANALOG I/P DISPLAY FS.

Specify the low engineering range as the ANALOG I/P DISPLAY ZERO.

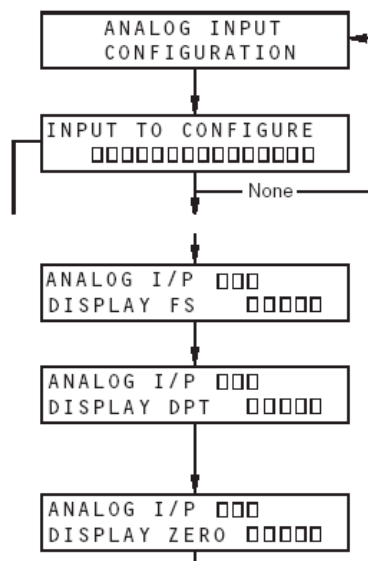

**Step 3:**

The next step is to obtain the Count Rate Value for the totalizer. To obtain the proper Count Rate Value for the totalizer, the Engineering Units (GPM, MGD, etc.) will need to be broken down to "Engineering Units per Second". Engineering High divided by the Count factor will equal the Count High Value. See Table 1 for the appropriate count factor.

**Table 1**

Eng. Units	Count Factor
EU Per Second	EU / 1
EU Per Minute	EU / 60
EU Per Hour	EU / 3600
EU Per Day	EU / 86400

The following examples explain the Count High Value calculation:

1. 2000 GPM should be converted to GPS i.e.  $2000 / 60 \text{ GPS} = 33.3333 \text{ GPS}$
2. 600 GPH will be  $600 / 3600 \text{ GPS} = 0.1667 \text{ GPS}$
3. 1,000,000 GPD will be  $1,000,000 / 86400 \text{ GPS} = 11.574 \text{ GPS}$

Enter the proper calculated Count Rate Value in Count High Field in the configuration/program menu.

Examples are listed below.

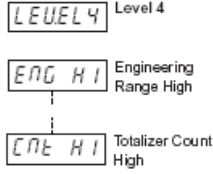
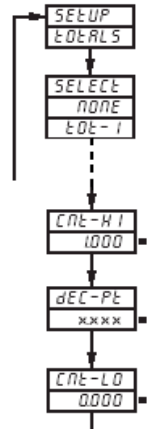
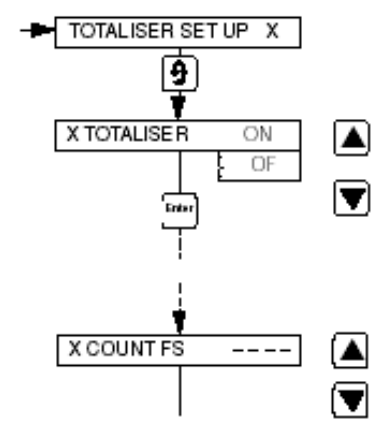
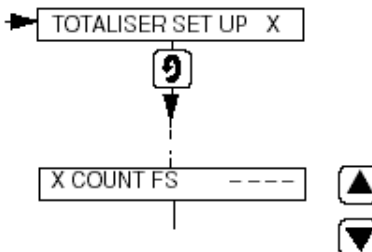
<p><b>C150, C160</b></p>	<p>Configure CnT HI in Level 4 of the configuration</p>	
<p><b>C 1900</b></p>	<p>In the Advanced Configuration Level, Setup Totals Menu configure the Cnt-HI <b>AdU.nCd COnFIG - SetUP tOtALS - Cnt-HI</b></p>	
<p><b>1492</b></p>	<p>In the Totalizer Setup Page, configure X - TOTALISER SET UP X - X COUNT FS</p>	
<p><b>SR250A, PR250</b></p>	<p>In the Totalizer Set Up page, configure TOTALIZER SETUP X – X COUNT FS</p>	

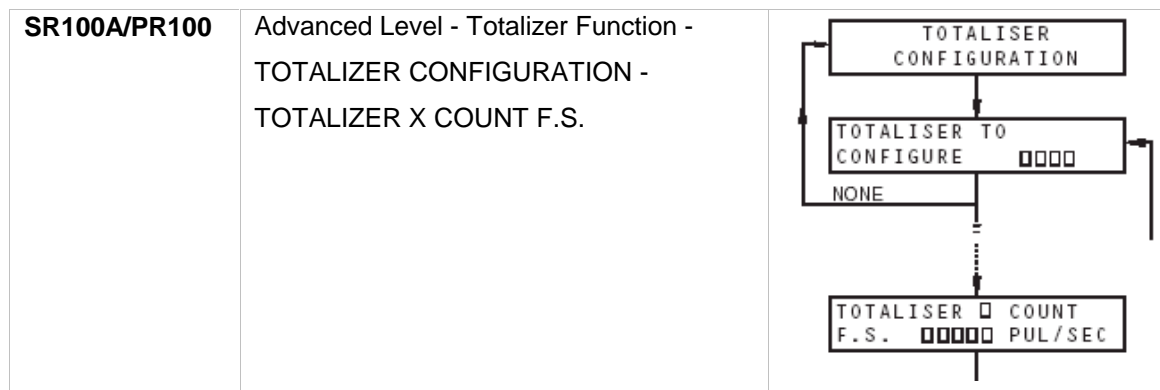

**Step 4:**

Sometimes a multiplier is required because of the limitation on the Count High Value that can be displayed on the instrument. A multiplier (x100, x1000) needs to be added to the totalizer value. For example, if 1 count on the totalizer is to represent 1000 then a x1000 multiplier is required. The totalizer value is to read **XXXXXXXX** x 1000, then divide The Count High Value by 1000. The next Table lists the totalizer value and the dividing factor to display the correct value.

**Table 2**

Totalizer Value	Divide Count high Value by
x 10	10
x 100	100
x 1000	1000
x 10000	10000

The following examples explain the totalizer multiplier value calculation:

We will use the High Eng. unit as 2000 GPM in this example.

1. Totalizer Reading x 1000 = 33.3333 / 1000 = 0.0333
2. Totalizer Reading x 100 = 33.3333 /100 = 0.333

Note: The totalizer Count Rate Values has limits to the amount of digits. If the original calculated Count Rate exceeds these limitations a multiplier, explained in step 4, may need to be utilized. See below for limitations. Refer to the following table for the limitations:

In most cases, the Count Low is Zero. The totalizer-preset value equals all zeros and the Predetermined Value equals zero.

Table 3

Instrument	Minimum Count Rate Value	Maximum Count Rate Value
C150, C160	0.001	99.999
C1900	0.1 0.01 0.000	100.0 or 10.00 or 1.000
1492, SR100A and PR100	0.01 0.001	10.00 or 1.000
SR250A, PR250	0.001	99.999