

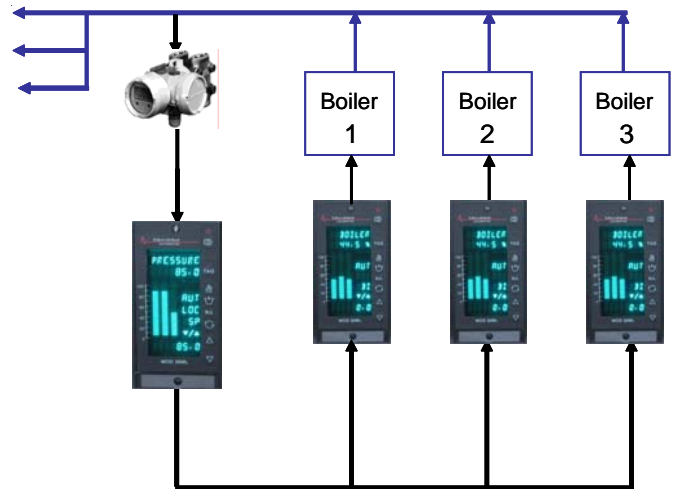

FEATURES

- *Provides supervisory steam setpoint to individual Boiler Master controllers*
- *Operate all boilers from a single point*
- *Quick response to large load changes*
- *Lead/Lag option brings boilers on line as needed*
- *Steam feedforward option anticipates demand changes*
- *Use with BoilerPAK, TrimPAK, MeterPAK or third-party combustion control system*
- *Hours-of-operation meter with Lead/Lag option*
- *Application-specific installation & operations documentation*

STEAMPAK Series PlantPAK Plant Master Controller



SYSTEM DESCRIPTION

PlantPAK is a pre-engineered, pre-configured control package that provides the master steam setpoint to multiple boilers. It can be used in conjunction with the SteamPAK combustion control packages or existing third party combustion controls.

The PlantPAK Plant Master controller receives the steam header pressure signal from the steam pressure transmitter, compares it to the plant pressure setpoint, and sends a modulating output to all the Boiler Master controllers to eliminate any pressure error when in Automatic mode. The operator may place the controller in manual and provide a manual plant demand.

A Lead/Lag option turns boilers on or off as the plant demand requires. When the pressure is below setpoint for a user-configured period of time, the controller starts the first (lead) boiler. The remaining boilers are brought on line based on the PlantPAK controller output rising above a predetermined value for a user-selected time period. A Start command is sent from the PlantPAK controller to each boiler's Burner Management System. A digital feedback signal from the BMS (Release-to-Auto) notifies the PlantPAK controller that the boiler is running. Once the lag boilers are running, the PlantPAK controller modulates all boilers in parallel.

If the PlantPAK does not receive the Release-to-Auto signal from the BMS within a predetermined time period, it will attempt to start the next boiler in the sequence. If the final sequence does not match the original configured sequence, the PlantPAK controller automatically changes its sequence and sequence indication to match the actual order in which the boilers start.

When the PlantPAK output drops below a user-configurable point for a selected time period, the PlantPAK begins taking the boilers offline in inverse order. The lead boiler will be shut down if the pressure is above setpoint for a user-configured time period. Logic in the PlantPAK program prevents two "lag" boilers from shutting down at the same time, unless locally commanded by the BMS (PlantPAK does not override the Burner Management System).

The Lead/Lag option also includes an Hours of Operation meter and display for each boiler, and indication of the number of days the current sequence has been in operation.

EQUIPMENT DESCRIPTION

Each PlantPAK includes:

- PlantPAK controller, pre-configured for automatic gain control of up to three Boiler Masters (customized PlantPAK is available for four or more boilers; contact MicroMod)
- All necessary documentation for the installation, startup and operation of the system.

The PlantPAK controller is a multiloop controller with flexible, isolated I/O and a high-visibility display with clear, informative screens for ease of operation. The base controller includes the CPU, power supply, display, and terminal block. The controller memory is non-volatile RAM which contains the configured database and all current process parameters. The terminal block provides direct connection of field wiring at the rear of the controller. The power supply is 85-250Vac and the front panel is NEMA 4. The controller also provides failsafe and power fail-recovery settings for all configured parameters and output points.

Other PlantPAK OPTIONS

Plant Steam Feedforward - includes one additional analog input for saturated steam flow, and uses total plant steam flow as a feedforward signal to the control loop. This option requires a steam flow measurement from the main header. *For superheated steam with temperature compensation contact MicroMod.*

Field Instrumentation - MicroMod can provide Steam Pressure and Steam Flow transmitters if required. Contact our Sales or Customer Service department for assistance.

Backup Memory Module - provides redundant, removable non-volatile RAM which backs up the controller database. In addition, if left on the controller during operation, it is updated every 50ms with current process data such as output values, controller mode, tuning parameters etc. This allows immediate re-start of the system after a power outage or equipment failure, with the latest values.

Custom Application Engineering - if the standard PlantPAK configuration doesn't meet your application needs, MicroMod will work with you to develop a cost-effective solution to improve your boiler plant operation.

The MicroMod SteamPAK SERIES

PlantPAK is just one of MicroMod's pre-engineered packages for industrial and institutional boiler controls. The SteamPAK family includes:

BoilerPAK - single-point jackshaft position control

DrumPAK - one, two- and three-element drum level control

TrimPAK - parallel positioning control with O₂ trim for jackshaft boilers. An ideal and economical way to upgrade a single-point positioning system to get maximum combustion efficiency.

BurnerPAK - Burner Management Systems

MeterPAK - Fully metered combustion control system with O₂ trim

Combustion control packages are also available for High Temperature Hot Water systems.

Plantwide System

All SteamPAK products can be integrated into a plant-wide, Ethernet-based system with advanced operator stations, alarm/event logging and reporting.

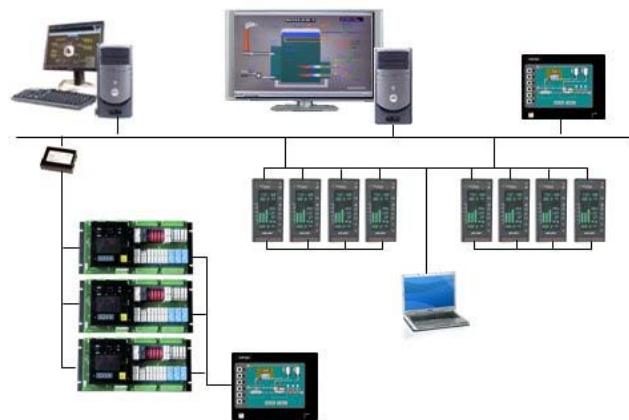

Analog Inputs (4-20mA, isolated, with transmitter power)

- Steam Header Pressure
- Steam Flow (with Steam Feedforward option only)

Digital Inputs (110Vac, isolated) - Lead/Lag option only

- Boiler 1 Running
- Boiler 2 Running
- Boiler 3 Running

Analog Outputs (4-20 mA, isolated)

- Boiler 1 Demand
- Boiler 2 Demand
- Boiler 3 Demand

Digital Output (110Vac, isolated) - Lead/Lag option only

- Boiler 1 Start
- Boiler 2 Start
- Boiler 3 Start

Relay Output (110Vac, isolated)

- Alarm Horn

Operating temperature: 0 to +50°C

Storage Temperature: -40 to +75°C

Humidity: 5 to 95% RH, noncondensing

Power Supply: 85-250V rms, 50-400Hz

Power Consumption (120V rms, 60Hz, Full load): 50W maximum

ORDERING INFORMATION

PlantPAK is a licensed package. The following end-user information must be supplied with each package ordered:

- End-user Company Name
- Complete Address
- Contact Name
- Telephone & Fax Number
- Email address

	PLT					
	01 - 03	04	05	06	07	08
PlantPAK Plant Master Controller for up to 3 boilers ¹	PLT					
Auxiliary Control Options						
None		0				
Automatic Lead/Lag sequence control		1				
Steam feedforward ²		2				
Automatic Lead/Lag sequence control and steam feedforward ²		3				
Reserved						
Reserved Character			0			
Mounting						
Standard				0		
Remote Faceplate				1		
Operator Language						
English					E	
Spanish					S	
Design Level						
Design Level						B

Note 1: for more than three boilers consult factory

Note 2: Steam feedforward requires signal from steam transmitter on plant outlet

Available Options:	
Blank Memory Module	2010PZ10000A
Field instruments (steam transmitters and measuring elements)	
Custom Application Engineering - per hour	

MOUNTING DIMENSIONS

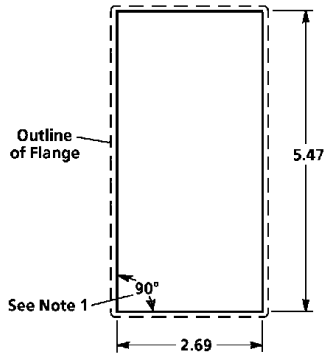

PANEL CUTOUT

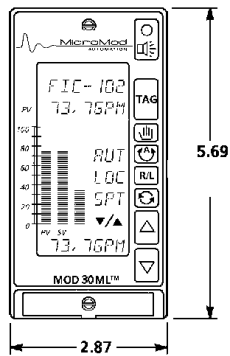
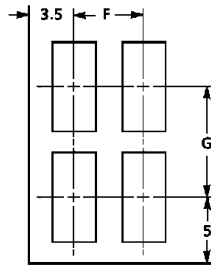

FRONT VIEW

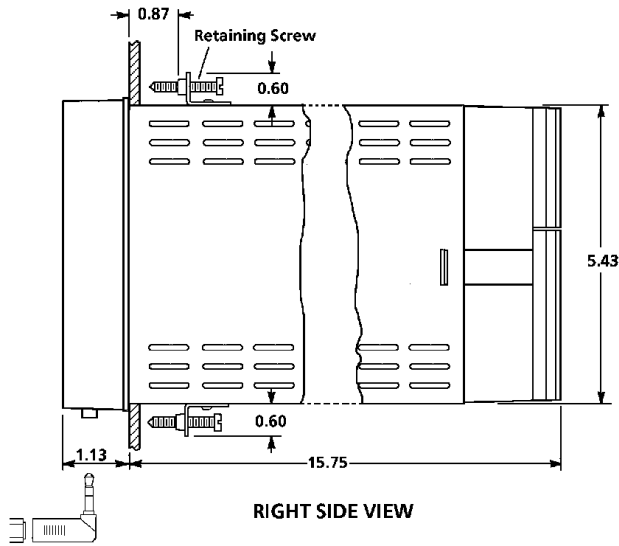

RIGHT SIDE VIEW

The Company's policy is one of continuous product improvement and the right is reserved to modify the information contained herein without notice.

Printed in USA November 2009

© MicroMod Automation, Inc. 2004

