

COMMISSIONING & STARTUP GUIDE

1	INTRODUCTION	1
2	SYSTEM DIAGRAMS	3
2.1	DRUMPAK 1 SINGLE ELEMENT CONTROL	3
2.2	DRUMPAK 2 TWO-ELEMENT CONTROL	3
2.3	DRUMPAK 3 THREE-ELEMENT CONTROL	5
3	INSTALLATION	7
3.1	DRUMPAK 1	7
3.1.1	<i>Input/Output Positioning – DrumPAK 1</i>	7
3.1.2	<i>I/O and Power Wiring - DrumPAK 1</i>	8
3.2	DRUMPAK 2	9
3.2.1	<i>Input/Output Positioning – DrumPAK 2</i>	9
3.2.2	<i>I/O and Power Wiring - DrumPAK 2</i>	10
3.3	DRUMPAK 3	11
3.3.1	<i>Input/Output Positioning - DrumPAK 3</i>	11
3.3.2	<i>I/O and Power Wiring - DrumPAK 3</i>	12
3.4	BUILT-IN ANALOG INPUTS	13
4	GENERAL OPERATIONS	15
4.1	VIEWING AND ACKNOWLEDGING ALARMS	15
4.2	OPERATING THE LOOP DISPLAY	16
4.2.1	<i>Drum Level Display</i>	16
4.2.2	<i>Steam Flow Display (DrumPAK 2 and DrumPAK 3 only)</i>	17
4.2.3	<i>Feedwater Flow Display (DrumPAK 3 only)</i>	18
4.2.4	<i>Control Keys</i>	19
4.2.5	<i>Operating the Auto and Manual Keys – Drum Level Controller</i>	19
4.2.6	<i>Operating the Clear Log Total Key – Steam Flow Controller (DrumPAK 2 and 3 only)</i>	19
4.2.7	<i>Operating the Clear Log Total Key – Feedwater Flow Controller (DrumPAK 3 only)</i>	20
4.2.8	<i>R/L Key</i>	20
4.2.9	<i>Operating the Scroll key</i>	21
4.2.10	<i>Operating the Ramp keys</i>	22
4.3	TUNING	23
4.3.1	<i>Tuning Password</i>	23
4.3.2	<i>Changing Tuning Parameters</i>	24
5	CONTROLLER INITIALIZATION	25
5.1	ACKNOWLEDGE AND CORRECT DIAGNOSTIC ALARMS	25
5.2	VIEW AND ACKNOWLEDGE PROCESS ALARMS	26
5.2.1	<i>Drum Level Loop Alarms</i>	26
5.2.2	<i>Quality Alarms</i>	27
5.3	VIEW AND VERIFY ACTUAL I/O VALUES	28
6	CONTROLLER SETUP	31
7	CONTROL LOOP TUNING PARAMETERS	35
7.1	DRUMPAK 1	35
7.2	DRUMPAK 2 AND DRUMPAK 3	36
8	FLOW CHARACTERIZATION	39
8.1	LINEAR VALVE	39
8.2	NON-LINEAR VALVE	39
8.2.1	<i>Obtaining characterization coordinates</i>	39

COMMISSIONING & STARTUP GUIDE

8.2.2	<i>Entering Characterization Curve Coordinates</i>	41
9	VERIFY FEEDWATER VALVE OPERATION	43
10	CLEAR TOTALS	45
10.1	STEAM FLOW TOTALIZER (DRUMPAK 2 AND DRUMPAK 3 ONLY).....	45
10.2	FEEDWATER FLOW TOTALIZER (DRUMPAK 3 ONLY)	47
	APPENDIX A SYSTEM DIAGRAMS	49
	APPENDIX B ORDER OF TUNING DISPLAYS	55
	APPENDIX C FEEDWATER VALVE CHARACTERIZATION TABLES	61
	APPENDIX D COMMUNICATIONS	63

1 INTRODUCTION

This guide provides instructions for startup and tuning of the DRUMPAK controllers. For more details on displays and key operation refer to the DRUMPAK Operating Guide. The available displays in the controllers are listed below.

Operating displays

- Drum Level (level control loop) – *all DrumPAK versions*
- Steam Flow (steam flow and total steam) – *DrumPAK-2 and DrumPAK-3 only*
- Feedwater Flow (feedwater flow and total feedwater) - *DrumPAK 3 only*

Tuning displays

DrumPAK-1 (single-element):

- Gain – Level
- Reset – Level
- Drum level engineering units – low
- Drum level engineering units - high
- Low level alarm trip point
- High level alarm trip point
- DrumPAK database version
- Feedwater valve characterization entries X1, Y1....X9, Y9

DrumPAK-2 and DrumPAK- (two- and three-element):

- Gain – Level (2 or 3 element) *DrumPAK-2 and DrumPAK-3 only*
- Reset – Level (2 or 3 element) *DrumPAK-2 and DrumPAK-3 only*
- Gain – Level (single element)
- Reset – Level (single element)
- Gain – Feedwater - *DrumPAK 3 only*
- Reset – Feedwater - *DrumPAK 3 only*
- Input linearization select – Steam *DrumPAK-2 and DrumPAK-3 only*
- Input linearization select – Feedwater *DrumPAK-3 only*
- Drum level engineering units – low
- Drum level engineering units - high
- Low level alarm trip point
- High level alarm trip point
- Steam flow engineering units – low *DrumPAK-2 and DrumPAK-3 only*
- Steam flow engineering units – high
- Steam flow constant
- Clear steam running total
- Feedwater flow engineering units – low - *DrumPAK 3 only*
- Feedwater flow engineering units – high - *DrumPAK 3 only*
- Clear feedwater running total - *DrumPAK 3 only*
- Single element switch value
- DrumPAK database version
- Feedwater valve characterization entries X1, Y1....X9, Y9

[Back to Index](#)

2.3 DrumPAK 3 Three-element control

The DrumPAK -3 controller contains two control loops: Drum Level and Feedwater Flow. The controller receives the input from the Drum Level transmitter and compares it to the local setpoint. The per cent Steam Flow signal is added to the output of the PID block as a feedforward signal, and this signal becomes the Remote Setpoint for the Feedwater Flow control loop. The controller receives the input from the Feedwater Flow transmitter and compares it to the remote setpoint, and generates an output representing feedwater flow demand. The output to the Feedwater valve is characterized in order to linearize the steam flow to the valve position. The controller will automatically switch from three element to single element at a user-selected low flow value (factory default is 10.0" H₂O).

The basic system is shown below. For SAMA diagrams refer to Appendix A.

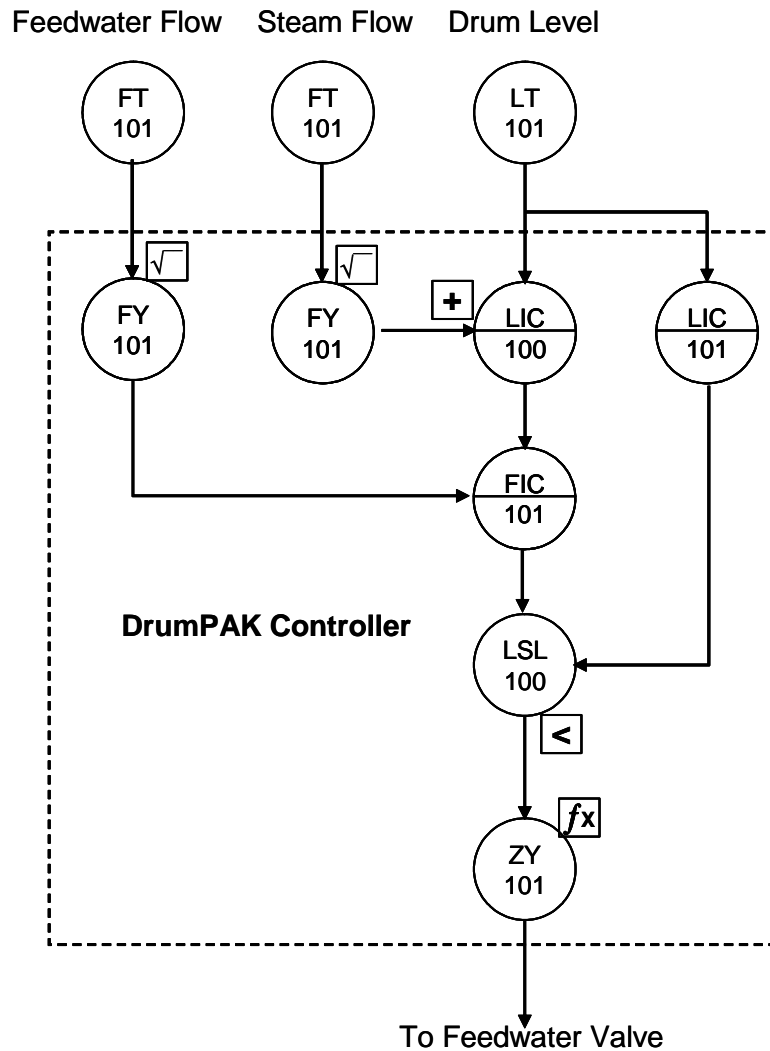

[Back to Index](#)

3.3 DrumPAK 3

The following diagrams illustrate the placement of the plug-in I/O modules, the optional memory module, and the optional RS-485 Modbus communication module for the DrumPAK 3 controller (three-element control).

3.3.1 Input/Output Positioning - DrumPAK 3

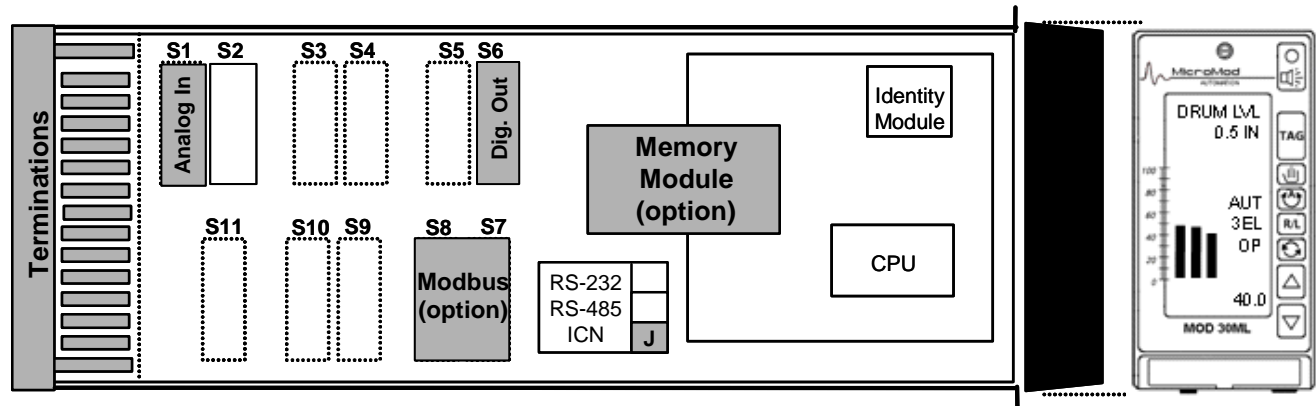

Position	Signal Type	Variable	Source/Destination
Built-In Analog Input #1	4-20 mA	Feedwater Flow	Differential Pressure transmitter or Vortex flowmeter
Built-In Analog Input #2	4-20 mA	Steam Flow	Differential Pressure transmitter or Vortex flowmeter
Built-In Analog Output #1	4-20 mA	Feedwater	Feedwater control valve
Built-In Analog Output #2	Not Used		
Built-In Communication Port	ICN	Peer-to-peer communication	Other SteamPAK controllers if present
POSITION 1	4-20mA 2012AZ10101B	Drum Level	Differential Pressure transmitter
POSITIONS 2 - 5	Not used		
POSITION 6	Digital Output 2005AZ21120A	Alarm	Annunciator
POSITIONS 7 - 8	Modbus RS-485 2034NZ10000B		Communication to PC (option)
POSITIONS 9 - 11	Not used		

[Back to Index](#)

COMMISSIONING & STARTUP GUIDE

3.3.2 I/O and Power Wiring - DrumPAK 3

The built-in analog inputs allow for either a differential pressure input (non-linear) or Vortex-type (linear) input. The built-in analog inputs are wired differently depending on what type of transmitter power is required or available. Please refer to the diagrams below, and to the Built-In Analog Input diagrams in Section 3.3, for correct wiring of analog inputs.

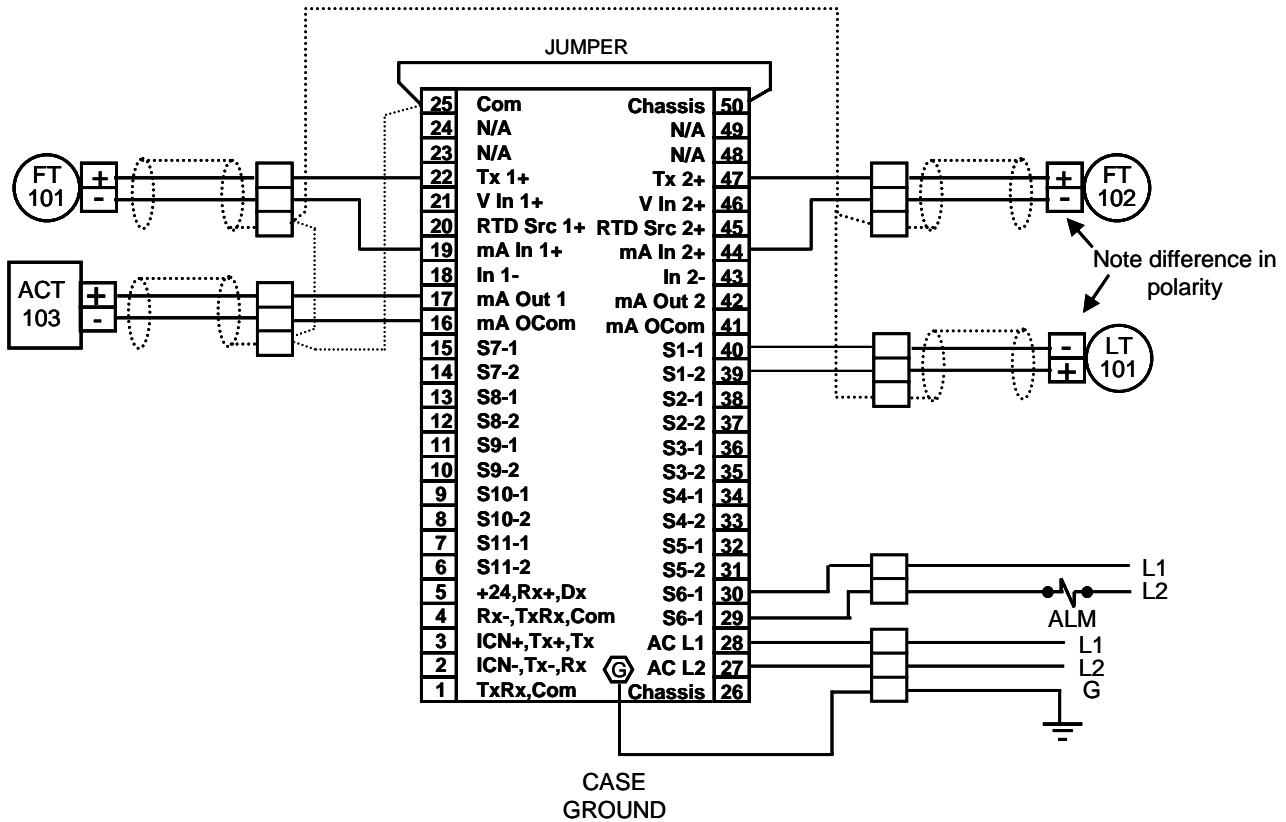

Notes:

- Pressure transmitter shown controller powered
- Built-in analog inputs and all analog modules must be grounded somewhere in the loop. Test negative wire to field instrument with voltmeter to determine if device is grounded in the field. If not, ground negative signal to instrument common.
- One ICN terminator 2030FZ is required for each ICN network. This should be installed on only one controller, at the end of the ICN network, as shown below:

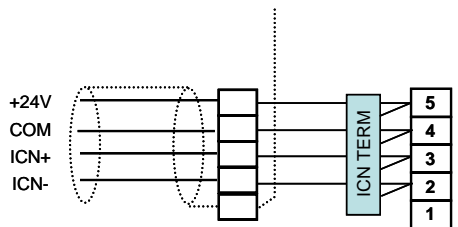

[Back to Index](#)

COMMISSIONING & STARTUP GUIDE

4.2 Operating the Loop Display

The loop operating display includes three 8-character alphanumeric lines, three alphanumeric status indicators, and three 50-segment bargraphs. The indicators are referred to in this document by line number (Line 1, Line 2 etc.)

The operational displays for the DRUMPAK system are explained below.

4.2.1 Drum Level Display

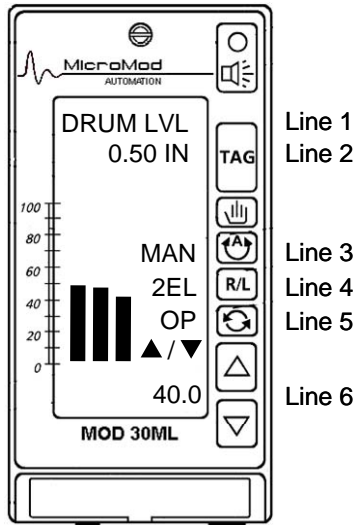

Left Bar indicates the Level in inches of water (IN)

Middle Bar indicates the Drum Level Setpoint

Right Bar indicates the output to the Feedwater valve

Line 1 indicates the loop tag

DRUM LVL

Line 2 indicates the Level in inches of water (IN)

0.0 IN

Line 3 indicates the control mode

MAN (manual)
AUT (automatic)

Line 4 indicates:

Local setpoint (DrumPAK 1)

LOC – DrumPAK 1

Single Element or 2 Element control (DrumPAK 2)

1EL (single) or 2EL

Single Element or 3 Element control (DrumPAK 3)

1EL (single) or 3EL (three element)

Line 5 indicates which variable is displayed on line 6

OP (output) or SP (setpoint)

Up/Down arrows indicate that the value on line 6 can be manually altered

▼/▲

Line 6 indicates the value of the variable on line 5

40.0%



Note: SP (setpoint) and its corresponding value indicate the setpoint of the Drum Level controller. OP (output) and its corresponding value indicate the output the Feedwater Flow Control Valve, regardless of whether the control type is single, two-element or three-element.

4.2.2 Steam Flow Display (DrumPAK 2 and DrumPAK 3 only)

This display shows the actual steam flow, the Running Total steam flow, and the Log (Shift) Total steam flow. The Log Total steam flow can be reset by the operator. The Running Total can only be reset from a Tuning display. *DrumPAK 1 does not provide this feature.*

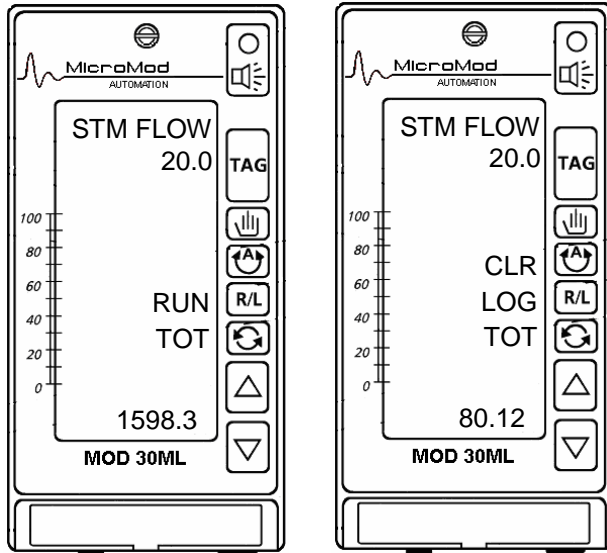

Line 1 identifies the variable

STM FLOW

Line 2 indicates the actual steam flow in thousands of pounds per hour (KPPH)

Line 3 is blank if Running Total is displayed, or CLR if the Log Total is displayed, indicating the AUT key is used to reset the Log Total.

Blank

CLR (clear key indicator)

Lines 4 and 5 indicate whether Line 6 displays the Running Total or Log Total steam flow.

RUN
TOT

LOG
TOT

Line 6 indicates either the Running Total steam flow or the Log Total steam flow.

1852.3

80.12

[Back to Index](#)

COMMISSIONING & STARTUP GUIDE

5.2 View and acknowledge process alarms

Standard process alarms are configured for Drum Level. When an alarm occurs it can be viewed by pressing the Alarm key, regardless of which operating display you are using. View and acknowledge process alarms using the method described in Section 2.1 of this Guide. Alarm displays are only visible when an alarm is active.

5.2.1 Drum Level Loop Alarms

Low Drum Level

Generates an alarm when Drum Level falls below the configured trip point.

The factory default value is -10.0 (inches of water); this value may have been changed during commissioning and startup.

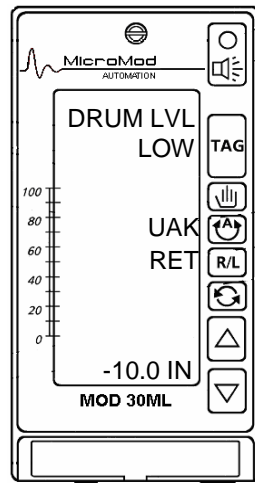

High Drum Level

Generates an alarm when drum level rises above the configured trip point.

The factory default value is 10.0 (inches of water); this value may have been changed during commissioning and startup.

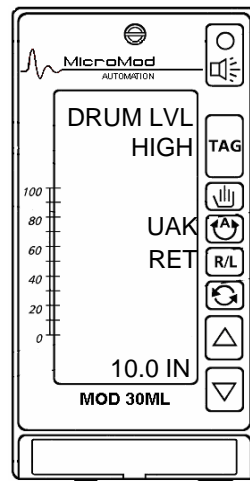

5.2.2 Quality Alarms

Drum Level Quality

Generates an alarm when there is no signal from the drum level transmitter, or when the signal is outside the established Quality Limits.

The default Quality Limits are $\pm 10\%$ of full range.

This alarm causes the controller to switch to Manual mode.

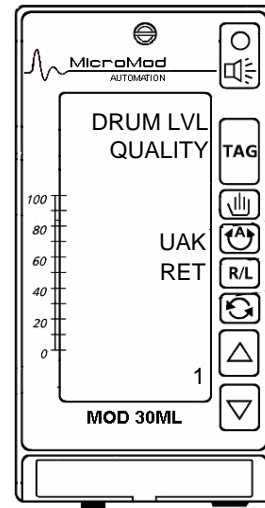

Steam Flow Quality (DrumPAK 2 and DrumPAK 3 only)

Generates an alarm when there is no signal from the Steam Flow transmitter, or when the signal is outside the established Quality Limits.

The default Quality Limits are $\pm 10\%$ of full range.

This alarm causes the controller to switch to Single Element control.

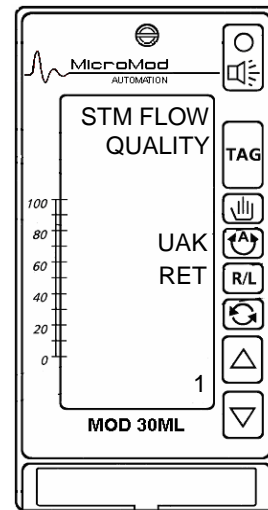

Feedwater Flow Quality (DrumPAK 3 only)

Generates an alarm when there is no signal from the feedwater flow transmitter, or when the signal is outside the established Quality Limits.

The default Quality Limits are $\pm 10\%$ of full range.

This alarm causes the controller to switch to Single Element control.

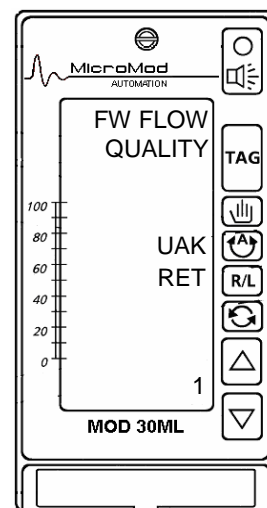

6 CONTROLLER SETUP



Press the TAG key

Lines 1 and 2 indicate DRUM LVL and the drum level in engineering units (inches of water)

Select the Steam Flow Linearization Type (DrumPAK 2 and DrumPAK 3 only):



Press and hold the Scroll key

Lines 1 and 2 display TUNE PASSWORD

Enter the tuning password **11** using the Auto and R/L (FST / SLO) keys and UP/DOWN keys. Press the Scroll key (ENT)

- Lines 1 and 2 display:
2 ELEMNT GAIN (DrumPAK 2) or
3 ELEMNT GAIN (DrumPAK 3)
- Line 6 shows the default gain value (0.6)

DO NOT CHANGE THE GAIN AT THIS TIME



Press the Scroll key next to the NXT indicator six (6) times

Note: the first time Tuning displays are accessed, the first screen in the order appears. Thereafter the last tuning display used appears.

- Lines 1 and 2 display STM LINZ TYPE
- Line 6 shows the default linearization type (MOD SQRT)

This display provides selection between Linear and Modified Square Root, depending on the type of element being used to measure Steam Flow and its signal output. Modified Square Root provides low-flow dropout calculation for differential pressure transmitters.



If a change is required, use the UP or DOWN key to change the linearization type to LINEAR or MOD SQRT

You must press the Scroll (ENT) key, for the controller to accept the new value.



Select the Feedwater Flow Linearization Type (DrumPAK 3 only):



Press the Scroll key next to the NXT indicator once

Note: the first time Tuning displays are accessed, the first screen in the order appears. Thereafter the last tuning display used appears.

- Lines 1 and 2 display FW LINZ TYPE
- Line 6 shows the default linearization type (MOD SQRT)

This display provides selection between Linear and Modified Square Root, depending on the type of element being used to measure Steam Flow and its signal output. Modified Square Root provides low-flow dropout calculation for differential pressure transmitters.



If a change is required, use the UP or DOWN key to change the linearization type to LINEAR or MOD SQRT

You must press the Scroll (ENT) key, for the controller to accept the new value.



COMMISSIONING & STARTUP GUIDE

Set the Drum Level engineering units (all DrumPAK versions):



Press the Scroll (NXT) key

- Lines 1 and 2 read DRUM LVL LOW ENG
- Line 6 shows the default value, -15.0

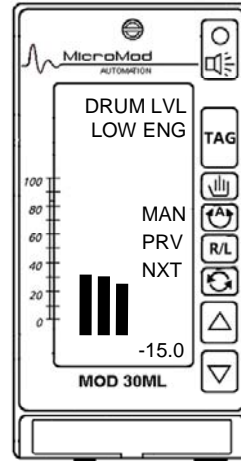

If a change is required, use the Auto (FST) and UP keys to enter the engineering unit range low value



You must press the Scroll (ENT) key, for the controller to accept the new value.



Press the NXT key

- Lines 1 and 2 read DRUM LVL HIGH ENG
- Line 6 shows the default value, 15.0



If a change is required, use the Auto (FST), R/L (SLO) and UP or DOWN keys to enter the engineering unit range high value



You must press the Scroll (ENT) key, for the controller to accept the new value.



[Back to Index](#)

8 FLOW CHARACTERIZATION

The method used for flow characterization is dependent on whether the feedwater flow control valve is Linear or Non-Linear. If the valve is linear, the Steam Constant "K" is used and the Valve Characterization table is left at default values (not used). If the valve is non-linear, the Steam Constant "K" is left at default value (not used) and the Valve Characterization Table must be completed.

Note: The Valve Characterization Table is available in DrumPAK 1, but is only used if a steam flow measurement is available. If Steam Flow is unavailable leave the table at Default value.

8.1 Linear Valve

For 2-element control (DrumPAK 2), the Steam Constant is used as a multiplier to normalize steam flow to feedwater valve position. For 3-element control (DrumPAK 3), the Steam Constant is used to normalize the steam flow range to the feedwater flow range, if these are different.

To change the Steam Flow constant:



Starting from the FEEDWATER HIGH ENG display, press the PRV key three times

- Lines 1 and 2 read STEAM K
- Line 6 shows the default value, 1.0

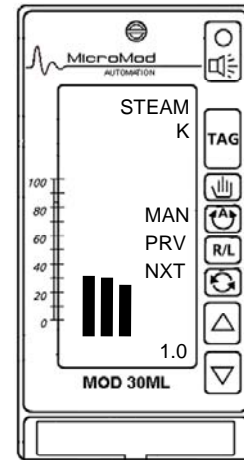

If a change is required, use the Auto (FST) and UP keys to enter the new Steam Constant



You must press the Scroll (ENT) key, for the controller to accept the new value.



8.2 Non-Linear Valve

This section explains the method of linearizing the steam flow to the feedwater valve position by varying the firing rate, stabilizing the level, and recording the parameters, then entering the resulting coordinates into the Valve Characterization table using the keys on the front panel of the DrumPAK controller. Appendix B provides a blank table for recording Level, Steam Flow, and Valve Output.

8.2.1 Obtaining characterization coordinates

At the Boiler Master controller, place the Boiler Master control loop in manual. With the Drum Level controller in AUTO, vary the firing rate at the front panel of the Boiler Master in 5% to 10% increments using the following method, then read and record the Drum Level, Valve Output, and Steam Flow.



Note: As a general rule, to increase firing rate manipulate the air output first, then the fuel output. To decrease firing rate, manipulate the fuel output first, then the air output.

Appendix C Feedwater Valve Characterization Tables

Note: If DrumPAK 1 is used, Feedwater Valve can only be characterized if some form of Steam Flow measurement is available. Otherwise these tables should be left at DEFAULT VALUES in the controller.

Load Variance Parameters

Shaded columns are used for X,Y lookup tables below.
Change in Level is used to calculate PID Gain factor.

Load	Level	Change in Level	Steam Flow		Valve Output
%	Inches of Water	% of Span	Eng. Units	% of Span	%
0%					
10%					
20%					
30%					
40%					
50%					
60%					
70%					
80%					
90%					
Full Load (100%)					

X,Y LOOKUP TABLES FOR DRUMPAK

Feedwater Flow Valve Characterization

Point	Steam Flow % Span	Point	Valve Output
X1		Y1	
X2		Y2	
X3		Y3	
X4		Y4	
X5		Y5	
X6		Y6	
X7		Y7	
X8		Y8	
X9		Y9	

[Back to Index](#)